

Manual

Simrad MX521A DGPS Sensor

English

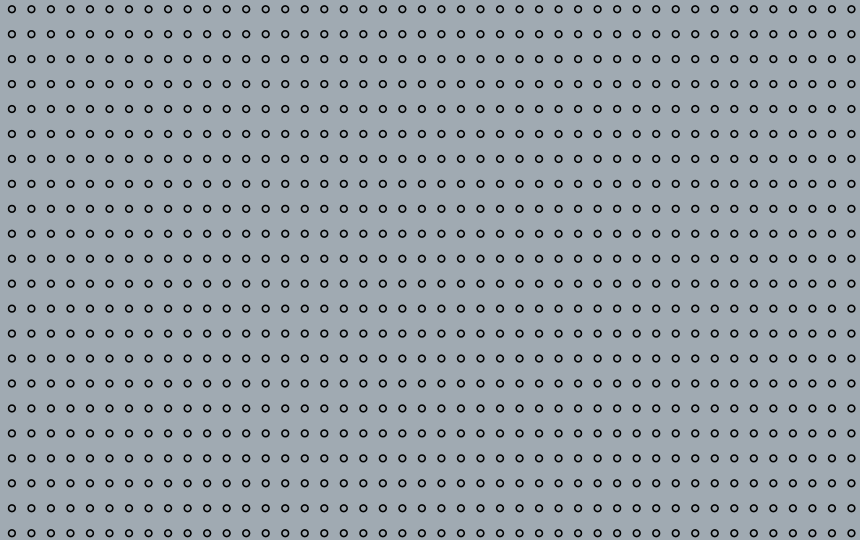

Manual

Simrad MX521A GPS/DGPS Sensor

English

Document no: 727052

Revision: A

Date: March 2008

The original language for this document is English. In the event of any discrepancy between translated versions and the English version of this document, the English document will be the official version.

To the best of our knowledge, the content in this publication was correct at the time of printing.

As we are continuously improving our products we retain the right to make changes to the product and the documentation at any time. Updated manuals are available from our website www.simrad-yachting.com, and are free to download.

© Copyright 2008 by Navico Holding AS.

IMPORTANT NOTICE!

THE MX521A GPS/DGPS SENSOR IS AN AID TO NAVIGATION ONLY. Under no circumstances should it be used in lieu of authorized government charts. Its accuracy can be affected by many factors such as equipment defects, environmental conditions, or improper operation. The user is responsible for safe navigation of the vessel. This includes consulting authorized government charts and exercising common prudence and navigational judgement at all times.

How to contact us?

Contact your local Simrad dealer for:

- Installation, Service, & Technical Support
- Sales of Accessories
- Hardware and Software Upgrades

Unlike many other consumer electronics industries which only sell consumer electronic devices, your marine dealer is often your best advisor for installation and service of your new GPS receiver. Simrad strongly encourages you to utilize the knowledge and experience of your sales and service dealer.

Should you need to contact us directly for new sales, upgrades, repair service, or technical support, we can be reached at the following:

International:

MX Marine (USA)
A Division of NAVICO, Inc.
23868 Hawthorne Blvd., Suite 201
Torrance, California 90505
USA
+1 310 791 8213 (Telephone)
+1 310 791 6108 (Fax)
www.mx-marine.com

In Europe:

Navico UK Ltd
Premier Way, Abbey Park
Romsey, Hampshire
SO51 9DH
United Kingdom
+44 (0)1794 510010 (Telephone)
+44 (0)1794 510006 (Fax)
www.navico.com

Contents

1 General	5
Supplied Equipment	6
2 Operation	7
General	7
Satellite Based Augmentation System (SBAS) ...	7
Receiver Autonomous Integrity Monitoring (RAIM)	8
3 Installation	9
MX521A Antenna Mounting Guidelines	9
MX521A Connector	10
Antenna Mounting	11
Antenna Cable Selection	13
Power Requirement	14
Antenna Cable Assembly	14
MX521A Connector Configuration	15
Data Interface to MX420/2 or MK12 CDU	16
Data Interface to MX420/8 or MX420/AIS CDU	17
Data Interface to PC or Other Navigation Systems	18
MX521A Programming Cable	19
Data Interface to MX5xx CDU	20
4 Specifications	21
5 Data Output	25

Blank page

1 General

This manual describes the operation and installation of the MX521A GPS/ DGPS and older version MX521 antenna sensors.

They were designed to work either interactively with MX Control and Display Unit (MX CDU) or as a stand-alone positioning device for other non-MX applications.

The MX521A smart DGPS antennas can achieve better than 2-meter DGPS accuracy in areas with good beacon differential coverage and autonomous GPS accuracy better than 5 meters.

When connected to an MX-CDU (i.e. MX420 or MX5xx), the MX521 can be controlled to function in several modes, namely;

- GPS only
- Differential correction search mode in Auto, Database or Manual
- WAAS* (Wide Area Augmentation System-US system)
- EGNOS* (European Geostationary Overlay System)
- RAIM (Receiver Autonomous Integrity Monitoring)

The MX521 sensors were designed to be used as:

- Source of GPS/DGPS positioning for MX CDUs including MX420 & MX5xx series CDUs
- Retrofit of IMO compliant GPS and AIS installation
- Source of position for ECDIS and other charting software

Before installing the MX521 smart antenna, please read this manual carefully to ensure proper installation and operation of the unit.

*Not yet recognized by IMO as official differential correction system

Supplied Equipment

The following items are supplied with the MX521A Kit:

Description	Part Number
MX521A GPS Sensor only	727050
or,	
MX521A DGPS Sensor	727051
Installation Manual	727011

The antenna cable assembly is not included and must be ordered separately. Please specify the cable length required. Below are available lengths in stock:

20 meters	3508 102 70170
40 meters	3508 102 70180
60 meters	3508 102 70640
80 meters	3508 102 70185



MX521A DGPS Sensor Kit

2 Operation

General

The MX521A DGPS sensor is an integrated GPS and beacon receiver unit that is fully automatic and usually does not require user intervention in most cases. It will automatically search for available satellites as soon as power is applied.



Not available with MX521A GPS only models.

The internal 2-channel beacon receiver initiates an Automatic Beacon Search (ABS) on power on for the first time. The primary channel will lock-on to the nearest beacon station, while the second channel searches for other available beacon signals. Should it find a superior signal, it will automatically switch the primary channel to the new station.

The MX521A beacon receiver can be controlled by a Control Display Unit (CDU) like an MX420 or MX500 series, to operate in Automatic Beacon Search mode, Manual Tune or Database mode. The Database mode allows the beacon receiver to pick 10 stations that are closest to your present position. This feature complies with the IEC 61108-4 specifications.

The combined performance of the high-precision 12-channel GPS and 2-channel smart beacon receiver provides a more accurate position fix, usually within 3 feet or less.

Satellite Based Augmentation System (SBAS)

In areas where land-based Coast Guard beacon stations are not available, the MX521 can be controlled (using the MX420 CDU) to track the Satellite Based Augmentation Systems (SBAS) like the WAAS (US), EGNOS (European) and MSAS (Japan) satellites. These satellites transmit DGPS correction data (just like the Coast Guard stations) using the GPS frequency. Refer to the MX420 Operator

Manual for more details. Turning this feature ON in the MX420 CDU will initiate the MX521 to listen for and track any SBAS satellites that are in view.

Receiver Autonomous Integrity Monitoring (RAIM)

RAIM is a special software algorithm in the MX521A program which gives the operator timely warnings when the GPS system accuracy is questionable. This feature requires at least five or more GPS satellites to operate properly. If the position solution error exceeds a preset limit a "RAIM Unsafe (R-)" or "RAIM Caution (R?)" alarm will be indicated in the MX CDU. This means that the accuracy of the position can not be guaranteed to be very accurate at that point in time. The operator is advised to use the GPS cautiously for navigation until the RAIM indicator switches to (R+) denoting safe RAIM condition.

Position errors may be caused by unhealthy satellites, incorrect pseudoranges, poor satellite geometry, excessive atmospheric interference and problems at particular reference stations.

3 Installation

MX521A Antenna Mounting Guidelines

The MX521A antenna housing is weather-resistant and must be located outside where it will have a good view of the sky around it. Use a standard 1"-14 TPI bracket for mounting.

- Install the MX521A antenna where it has a clear view of the sky around it.
- Locate the antenna for easy access and maintenance.
- Stay away from high-power energy sources such as radar, SSB, INMARSAT and other transmitting radio antennas by 5 meters or more.
- Locate the antenna at least 10 meters away from and out of the transmitting beam of radar, INMARSAT and other high-power transmitters.
- Mount the antenna low to avoid excessive position and speed errors while underway.
- Mount the antenna as far away as possible from large metal structures.
- Mount the antenna about 1 meter away from the compass.



If you are not sure if the chosen location is appropriate, you can mount the antenna temporarily and operate it with the MX420 CDU. Monitor the operation of the MX521A while you turn on other on-board electronic equipment. Move the antenna around until the MX521A operates satisfactorily then mount it permanently.

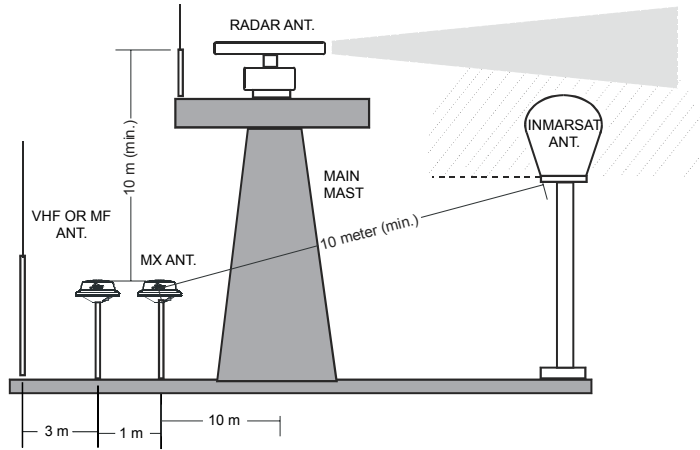

MOUNT THE MX521/421
10 m (min.) FORWARD OF MAIN MAST

MX521A Connector

The 10-pin male connector located at the underside of the antenna unit provides the means to connect to external power and the data interface. Please refer to the chart below for the pin numbers, wire colors codes and signal assignments.

Pin #	Wire Color	MX521A DGPS Antenna	MX521A GPS Antenna
1	BLK	Negative Ground	
2	RED	+9 - 32 VDC	
3	BLU	MX Proprietary Message (MPM In (-))	
4	BRN	MX Proprietary Message (MPM In (+))	
5	ORG	GPS Out (-)	
6	GRN	GPS Out (+)	
7	YEL	Beacon Status Out (-)	Not used
8	WHT	Beacon Status Out (+)	Not used
9	PRPL	RTCM IN (+)	
10	PRPL/ GRY	RTCM IN (-)	

Antenna Mounting

Bracket Mount

The MX521A mounting thread is an industry standard fitting for VHF antenna mounting (1inch, 14 TPI). This enables the antenna to be mounted on a wide range of mounting brackets, including the swivel joints, commonly used for angled surface. Refer to the figure below for bracket mounting illustration.



Hand-tighten the antenna onto the bracket until snug. Do not overtighten.

A 10-pin (male) plastic connector is mounted at the underside of the antenna for power and data connection.

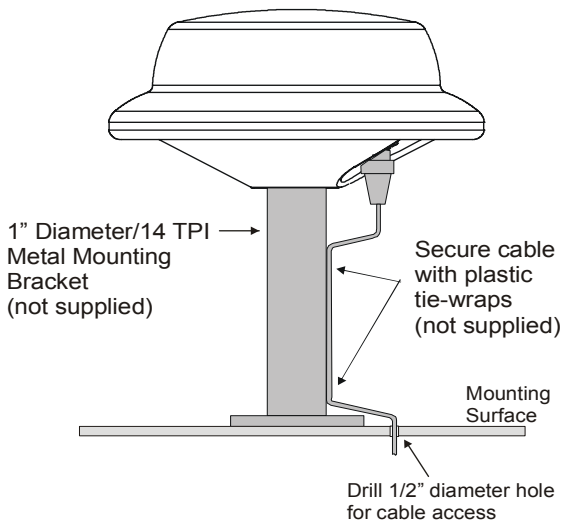

MX521A Bracket Mounting

Surface Mount

The MX521A can also be surface-mounted. Make sure there is at least 5-inch clearance underneath the mounting surface to accommodate the lower section of the MX521A housing, connector and cable. Refer to the figure below for surface mounting considerations. Cut a 5

1/4 inch diameter hole on a horizontal mounting surface and drill the four mounting screw holes as shown.

Fasten the antenna by using 2-mm size stainless steel metric screws (4 places). Use a marine grade caulking compound to seal between the mounting surface and the bottom of the antenna housing.

Choose a location for the antenna that has a clear view of the sky. Make sure there are no major obstructions or metal fixtures in the immediate proximity to the antenna. The GPS antenna relies on direct 'line-of-sight' signal reception. If you are unsure if the chosen location is suitable, it is advisable to mount the antenna in a temporary manner to verify correct operation.

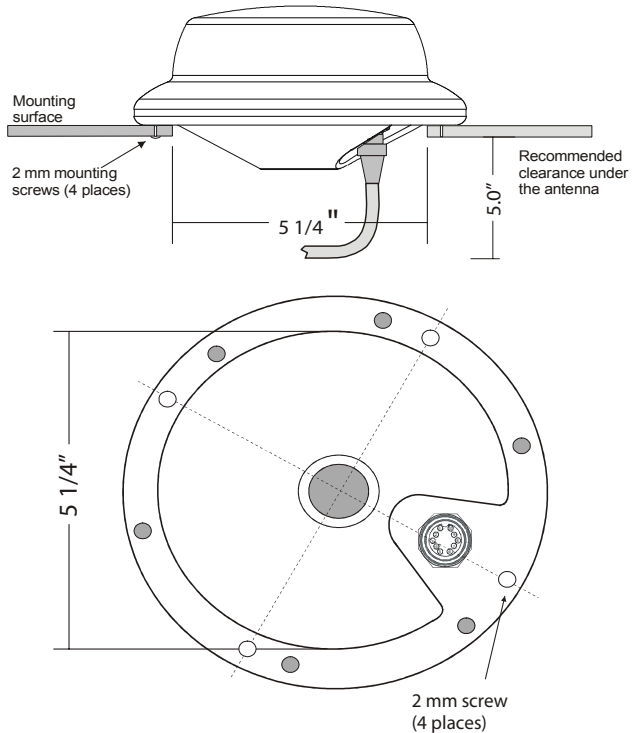

MX521A Surface Mount

Antenna Cable Selection

The antenna cable assembly for the MX521A antenna is not included in the kit and must be ordered separately. Several cable lengths are available in stock. To assist you in ordering the correct cable length, please refer to the antenna cable list below for cable description and part number.

Part Number	Description
-------------	-------------

Antenna Cable with One 10-Pin Connector (for all models):

3508 102 70170	20 meter
3508 102 70180	40 meter
3508 102 70640	60 meter
3508 102 70185	80 meter

Antenna Cable with both ends terminated with 10-Pin Connectors (for MX5xx Series):

500 100 1006	20 meter
500 100 1007	40 meter

Power Requirement

External power supplied to the MX521A must be within 10.5-32 VDC for best operation. To protect the circuitry in the MX521A, the voltage level must be within these limits. Negative grounding is required. The MX521A draws less than 300 mA. at 12 VDC. An in-line fuse or circuit breaker rated at 2 amp. is recommended for overload protection.

When the MX521A is connected to an MX control and display unit (CDU), the 12 VDC antenna power is supplied by the CDU unit.

The red wire connects to the (+) DC power, while the black wire is the negative return. Although the MX521A has a reverse polarity protection, it is prudent to make sure that proper polarity is observed before making the connection.



Reverse polarity connection may damage the unit.

Antenna Cable Assembly

Below is a diagram showing the pins and wire color-coding of the antenna cable assembly.

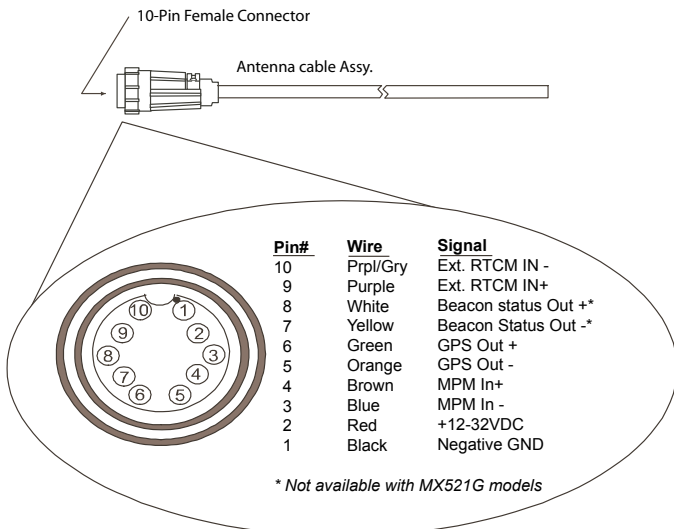

Power/Data Cable Assembly

MX521A Connector Configuration

Refer to the diagram below for the POWER-DATA connector located at the underside of the MX521A :

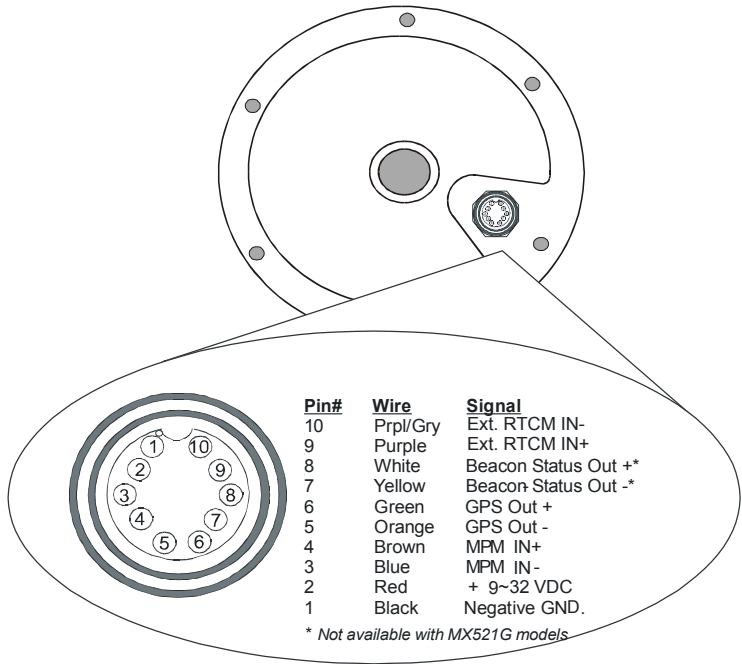

MX521A POWER-DATA Connector

Where:

- Pins 1 & 2: Negative GND and +12 VDC power input.
- Pins 3 & 4: MX proprietary message (MPM) input port.
- Pins 5 & 6: GPS output to the MX420 or other NMEA 0183 compatible devices.
- Pins 7 & 8: Beacon monitoring signal output. Sends the SNR, Signal and Frequency to the MX420/8 CDU. Connects to Cable B of the MX420/8 CDU.
- Pins 9 & 10: External RTCM Correction (Input).

Data Interface to MX420/2 or MK12 CDU

Use the diagram below to interface the MX521A to an MX420/2 or MK12 CDU.

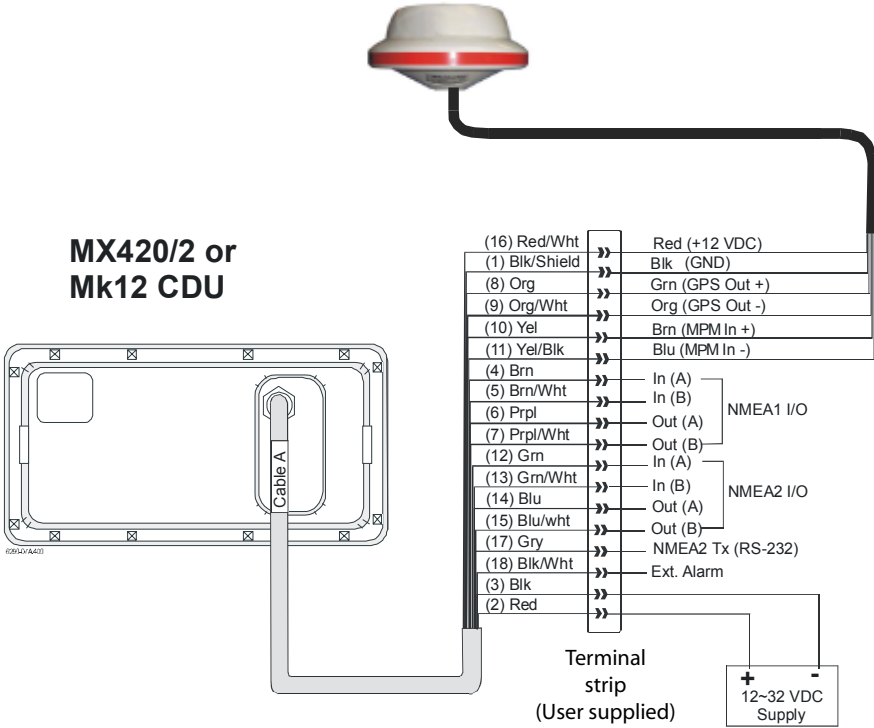

MX521A Interface to MX420/2 or MK12 CDUs

Data Interface to MX420/8 or MX420/AIS CDU

Use the diagram below to interface the MX521A to an MX420/8 or MX420/AIS CDU. The external RTCM connection is optional.

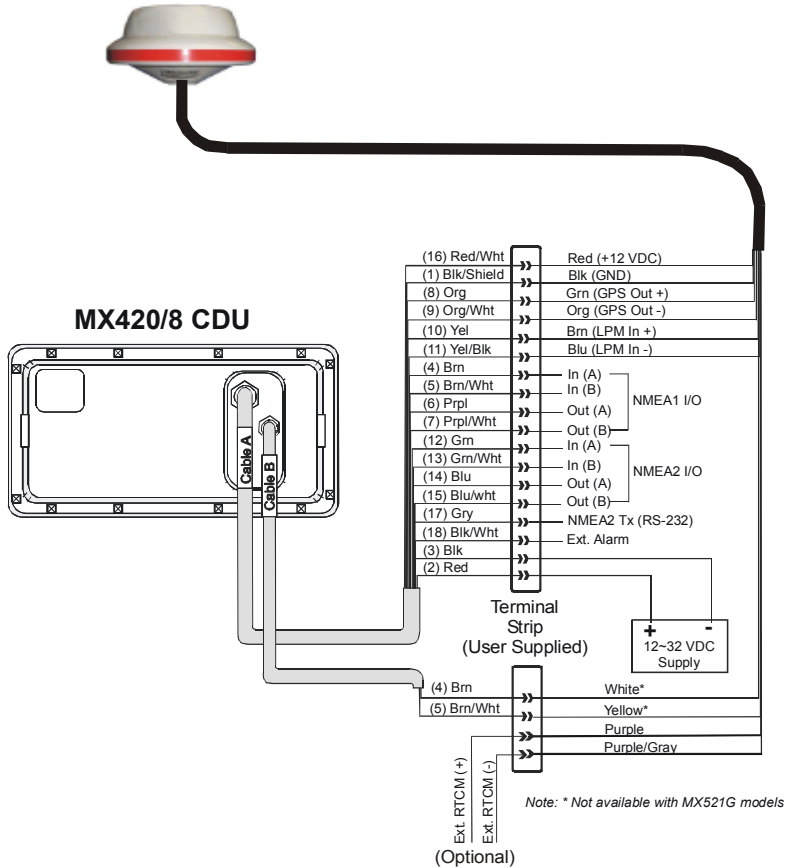

MX521A Interface to MX420/8 or MX420/AIS CDUs

Data Interface to PC or Other Navigation Systems

The figure below shows the power and data output connections to the serial port of a PC or other navigation systems using a dB9 connector and a terminal strip (user supplied items).

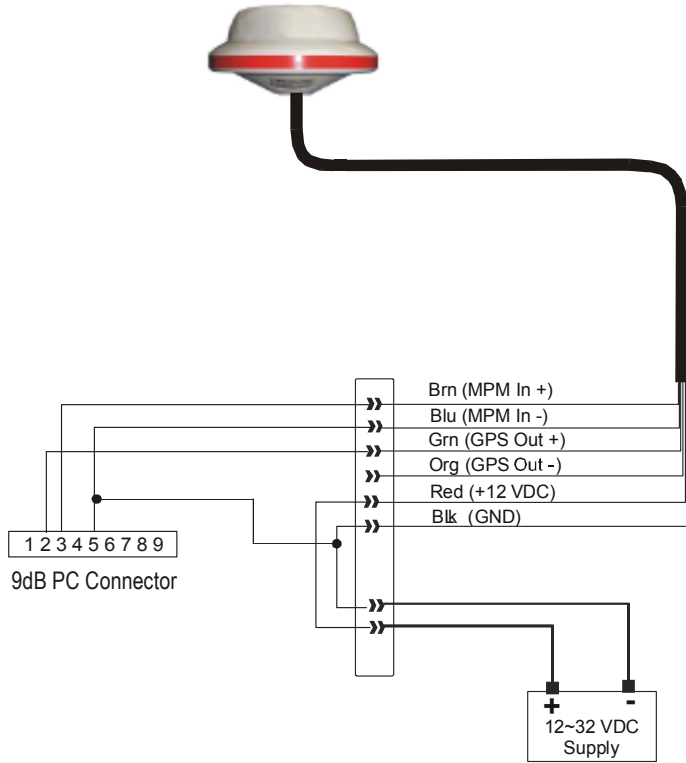

MX521A Interface to Other Navigation Systems

MX521A Programming Cable

The programming cable is used for upgrading the software of the GPS and Beacon PCBs inside the MX521A smart antenna. The figure below shows the programming cable diagram and equipment setup. Please note that external 12 volt DC is required to power up the MX521A. Connect the red wire to +12 VDC and Black wire to negative GND. The RS422-RS232 converter may be powered from the PC serial port or from an external 12 volt power supply.

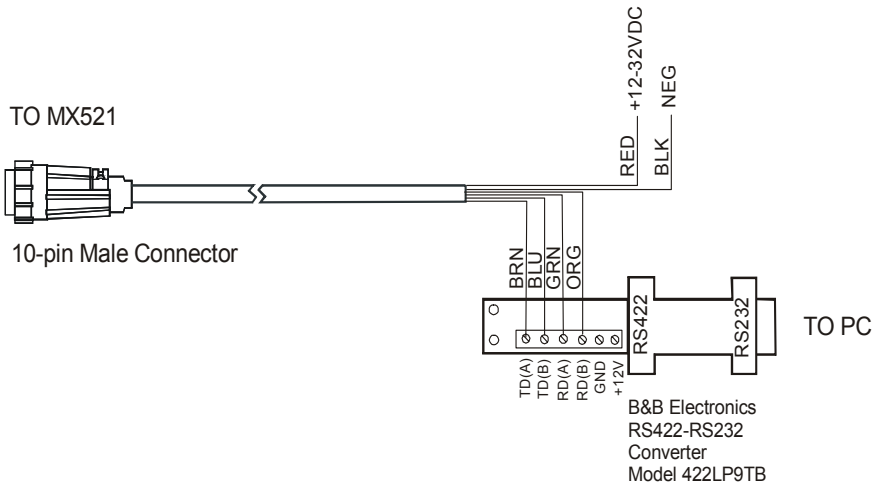

MX521A Programming Cable Diagram

Data Interface to MX5xx CDU

Use the diagram below to interface the MX521A to an MX500, MX510 or MX512 CDU. Antenna cable assembly with two 10-Pin connectors are available in 3, 20 and 40 meter lengths.

MX5xx CDU

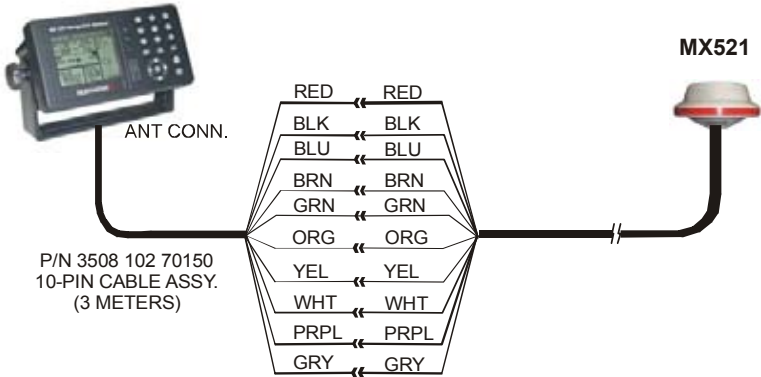

MX5xx CDU

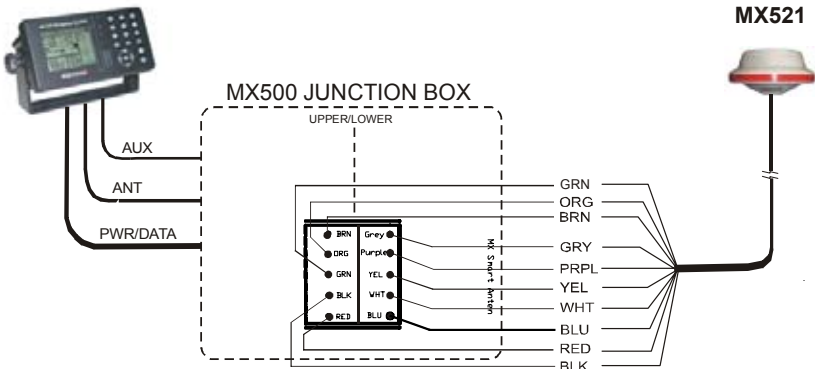

NOTE: OTHER COMPONENTS AND CONNECTIONS IN THE MX 500 JUNCTION BOX ARE NOT SHOWN

MX5xx Antenna Interface to MX521A

4 Specifications

GPS Receiver

Type: L1, C/A Code (SPS) with carrier phase smoothing
Frequency: 1575.42 MHz
Channels:12 Channels, parallel tracking
Update rate: 1 Hz
RTCM Input: RTCM SC-104 format
Satellite measurement use: 12 channel parallel automatic selection
Antenna type: Ceramic Patch
Dynamic Range: 90 dB
Time to first fix:
 Cold start (no almanac or RTCM): 60 second (typical)
 Reacquisition..... <10 second (typical)
Position accuracy:
 With differential corrections from:
 Beacon Stations: <1 meters (2D-RMS) typical depending on distance from differential base station.
 Without differential corrections ... <3 meters (2D-RMS) (with S/A off)
Serial Ports: 2 duplex NMEA 0183 ports
BAud Rates: 4800 (default), 9600, 19200
Data I/O Protocol: NMEA 0183 V3.0
Correction I/O Protocol:RTCM SC-104
Datum: WGS84
NMEA messages: GGA, GRS, GSA, GSV, GST, RMC, VTG, ZDA & PMVXG,GBS (MX Marine proprietary)

Beacon Receiver (MX521A DGPS model only)

Frequency: 283.5 to 325.0 kHz. 2-channel Auto or Manual selection (500 Hz steps)
Sensitivity:2.5 uV/m for 6dB SNR @ 200 bps
Operating Modes: Automatic, Manual or Database
Dynamic Range:100 dB
Adjacent Channel Rejection:61 dB @ $f \pm 400$ Hz

Channel spacing:500 Hz
Frequency offset tolerance: \pm 5 Hz
Antenna type: H-Field
MSK rates:50, 100 and 200 bps

Environmental

Operating temperature:..... -30 to +70 °C
Storage Temperature: -40 to 85 °C
Humidity: "Exposed Category" (IEC 60945)

Mechanical

Dimensions:

Height 102 mm (4.0 in.)
Diameter 182 mm (7 1/8 in)

Weights: (MX521A DGPS) 820 grams (1.8 lbs.) (without cable)
(MX521G) 600 grams (1.3 lbs.) (without cable)

Mount: 1"-14 TPI pole mount
Surface mounting 5 1/4 " hole

Electrical

Operating voltage range:..... 10.5 to 32 VDC
Operating current: < 230 mA at 12.0 VDC,
Power Consumption: <3 Watts

Certifications

BSH and Wheelmark approval IMO MSC 112(73)

IEC 61108-4, IEC 60945 ed. 3, CE and FCC compliant

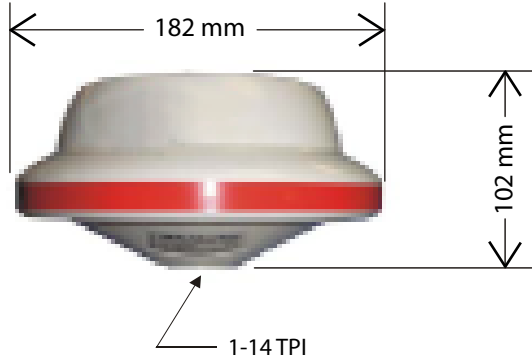

Simrad reserves the right to make changes in its products and specifications without notice.

Blank page

5 Data Output

The MX521A data output conforms to the NMEA 0183 V3.0 at 4800 baud. Below is a list of the NMEA sentences output:

GGA, GSA, GSV, GST, RMC, VTG and PMVXG,GBS (an MX proprietary sentence used for RAIM)

NMEA 0183 Data Output Sentences

(1) **GGA** - Global Positioning System Fix Data

Time, position and fix related data for a GPS receiver.

```
$GPGGA,hhmmss,llll.llll,a,yyyyy.yyyy,a,x,xx,x.x,x.x,M,x.x,M,x.x,xxxx*hh<CR><LF>
```

1	2	3	4	5	6	7	8	9	10	11	12	13	14
---	---	---	---	---	---	---	---	---	----	----	----	----	----

Notes: 1 ----- UTC of position

2,3 --- Latitude - N/S

4,5 --- Longitude - E/W

6 ----- GPS Quality Indicator:

0 = Fix not available or invalid

1 = GPS SPS Mode, fix valid

2 = Differential GPS, SPS Mode, fix valid

3 = GPS PPS Mode, fix valid

7 ----- Number of Satellites in use, 00-12, may be different from the number in view

8 ----- Horizontal Dilution of Precision (HDOP)

9 ---- Antenna altitude/mean-sea-level (geoid)

10---- Units of antenna altitude, Meters

11,12- Geoidal Height, Meters

13---- Age of Differential GPS Data

14 --- Differential Reference Station ID

(2) **GRS** - GNSS Range Residual

This message is used to support RAIM.

```
$GPRGS,hhmmss,x,x,x,x,x,x,x,x,x,x,x,x,x,x,x,x,x,x,x*x*hh<CR><LF>
```

1	2	3

Notes: 1 ---- UTC time of GGA or GNS fix associated with this sentence

2 ---- Mode 0 = residuals were used to calculate the position given in the matching GGA or GNS.

1 = residuals were computed after the GGA or GNS position was computed.

3 ---- Range residuals in meters for sat. used in navigation solution. Order must match the order of the satellite ID numbers in GSA. When GRS is used GSA and GSV are generally required.

(3) **GSA** - GPS DOP and Active Satellites

GPS receiver operating mode, satellites used in the navigation solution reported by the \$GPGGA sentence, and DOP values.

```
$GPGSA,a,x,xx,xx,xx,xx,xx,xx,xx,xx,xx,xx,xx,xx,x,x,x,x*x*hh<CR><LF>
```

1	2	3	4	5	6	7	8	9	10	11	12	13	14	15	16	17

Notes: 1---- Mode: M = Manual, forced to operate in 2D or 3D Mode

A = Automatic, allowed to automatically switch 2D/3D

2 ---- Mode: 1 = Fix not available, 2 = 2D, 3 = 3D

3-14 -PRN numbers of satellites used in solution (null for unused fields)

15 ---PDOP

16 ---HDOP

17 ---VDOP

(4) **GSV** - GPS Satellite in View

Number of satellites (SV) in view, PRN numbers, elevation, azimuth and SNR values. Four satellites maximum per transmission, additional satellite data sent in second or third message. Total number of messages being transmitted and the number of the message transmitted are indicated in the first two fields.

```
$GPGSV,x,x,xx,xx,xx,xxx,xx,.....,xx,xx,xxx,xx*hh<CR><LF>
  T T T T T T T T T T T T
  1 2 3 4 5 6 7 8 9 10 11 12
```

- Notes:
- 1 -----Total number of messages, 1 to 3
 - 2 ---- Message number, 1 to 3
 - 3 ---- Total number of satellites in view
 - 4 ----- Satellite PRN number
 - 5 ----- Elevation, degrees, 90 degrees maximum
 - 6 -----Azimuth, degrees True, 000 to 359
 - 7 -----SNR (C/No) 00-99 dB, null when not tracking
 - 8 -----2nd and 3rd SV
 - 9,10,11,12 - 4th SV

(5) **RMC** - Recommended Minimum Specific GPS Data

Time, date, position, course and speed data provided by a GPS navigation receiver. This sentence is transmitted at intervals not exceeding 2 seconds. All data fields must be provided: null fields used only when data is temporarily unavailable.

```
$GPRMC,hhmmss.ss,A,lll.llll,a,yyyy.yyyy,a,x.x,x.x,xxxxxx,x.x,a*hh<CR><LF>
  T T T T T T T T T T T T
  1 2 3 4 5 6 7 8 9 10 11
```

- Notes:
- 1 ---- UTC of Position fix
 - 2 ---- Status: A = data valid
V = Navigation receiver warning
 - 3,4 -- Latitude, N/S

- 5,6 -- Longitude, E/W
- 7 ---- Speed over ground, knots
- 8 ---- Course Over Ground, True
- 9 ---- Date: dd/mm/yy
- 10,11 - Magnetic variation, degrees E/W.
Easterly variation (E) subtracts from
True course, Westerly variation (W) adds
to True course.

(6) **GST** - GNSS Pseudorange Error Statistics

This message is used to support Receiver Autonomous Integrity Monitoring (RAIM). Pseudorange measurement error statistics can be translated in the position domain in order to give statistical measures of the quality of the position solution.

If only GPS, GLONASS, etc. is used for the reported position solution, the talker ID is GP, GL, etc., and the error data pertains to the individual system. If satellites from multiple systems are used to obtain the reported position solution, the talker ID is GN and the errors pertain to the combined solution.

\$GPGST,hhmmss.ss,x.x,x.x,x.x,x.x,x.x,x.x,x.x*hh<CR><LF>

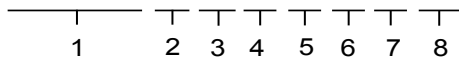

- Notes:
- 1 ---- UTC time of the GGA or GNS fix associated with this sentence.
 - 2 ---- RMS value of the standard deviation of the range inputs to the navigation process. Range inputs include pseudoranges & DGNSS corrections.
 - 3 ---- Standard deviation of semi-major axis of error ellipse (meters)
 - 4 ---- Standard deviation of semi-minor axis of error ellipse (meters)
 - 5 ---- Orientation of semi-major axis of error ellipse (degrees from true north)
 - 6 ---- Standard deviation of latitude error (meters)

- 7 ---- Standard deviation of longitude error (meters)
- 8 ---- Standard deviation of altitude error (meters)

(7) **VTG** - Course Over Ground and Ground Speed

The actual course and speed relative to the ground.

```
$GPVTG,x.x,T,x.x,M,x.x,N,x.x,K,a*hh<CR><LF>
  T T T T T T T T T
  1 2 3 4 5 6 7 8 9
```

- Notes:
- 1,2 ---- Course over ground, degrees True
 - 2,3 ---- Course over ground, degrees Magnetic
 - 5,6 ---- Speed over ground, knots
 - 7,8 ---- Speed over ground, km/hr
 - 9 ----- Mode indicator: A = Autonomous mode
 D = Differential mode
 E = Estimated (DR)
 M = Manual input mode
 S = Simulator mode
 N = Data not valid

(8) **ZDA** -Time and Date

UTC, day, month, year and local time zone

```
$GPZDA,hhmmss,xx,xx,xxxx,xx,xx*hh<CR><LF>
  _____ T T T T T
  1     2 3 4 5 6
```

- Notes:
- 1 --- UTC
 - 2, 3, 4 --- Day, month & year
 - 5 --- Local zone hours, 00 to ± 13 hrs.
 - 6 --- Local zone in minutes, 00 to +59.

How are we doing?

Please help us to help you and our other valued customers by sending us your evaluation of this manual. We need to know such things as:

- is the manual complete, or do you need more (or less) information?
- can you find the information you need easily?
- is the information easy to understand, or could we be clearer?
- are there any errors and, if so, where and what are they?

Be sure to reference the title and identification number of this manual.

Please email your comments to: tech.writing@navico.com.

We look forward to finding out how we can improve our information services.

All of your comments and suggestions become the property of Navico Holding AS.

Blank page

